



Designers. Manufactures and Professional Advisors in Height Safety, Controlled Access and Retrieval Systems,  
Accredited to International Safety Standards

## L4543 Roof Anchor For Steel Purlin Roofs with Steel Roofing Fitting Instructions



This Roof anchor complies with the requirements of AS/NZS 1891.1. It is able to sustain a load of 22kN and will distort if a load such as may occur during a fall is applied.

### Notes:

- **Capital Safety Group cannot warrant the roof structure. If in doubt, consult an engineer or the strut/roof frame manufacturer to verify structural adequacy prior to installation.**
- **It is recommended that all anchors only be fitted by competent persons.**
- **All roof anchors are required by law to be inspected and recertified annually. Further details can be obtained from AS/NZS 1891.4:2000, or contact Sala on 1800 245 002.**

**THESE INSTRUCTIONS SHOULD BE READ IN FULL BEFORE  
COMMENCING INSTALLATION**

**Sala Roof Anchors can be installed during roof construction, or retrofitted from above or below the roof sheeting any time after construction.**

## **Preparation**

The Threaded Eye Bolt Assembly (150mm) is made up of 3 components:

- (a) an eye bolt with 16mm threaded bar
- (b) a 25 mm x 50mm stainless tube
- (c) 1 x M16 relieved nut

Assemble these components as shown in diagram one, ensuring the relieved side of the nut is located within the stainless steel tube, and tighten by hand.

### **Diagram One**

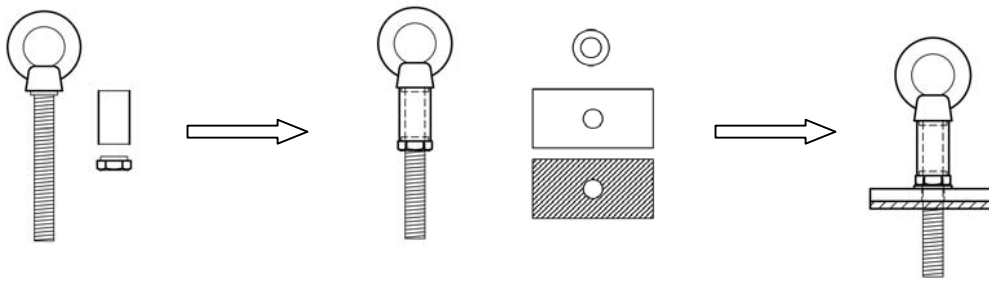

Fit the nylon washer to the threaded bar, followed by the 50mm x 10mm x 100mm plate polished side up, and finally the neoprene rubber gasket. The roof anchor is now ready for installation.

The roof anchor can be installed from either above or below the roof surface as detailed below.

## Option A: Fitting while on the top of the roof

**Step One:** Select the position for drilling at the centre of purlin, then use a 32mm hole saw to drill through the roof sheeting and purlin.

**Step Two:** Thread the plastic tie through the small hole in the elongated threaded nut and secure it. Whilst firmly holding the plastic tie, slip the elongated nut through the 32 mm hole.

### Diagram Two

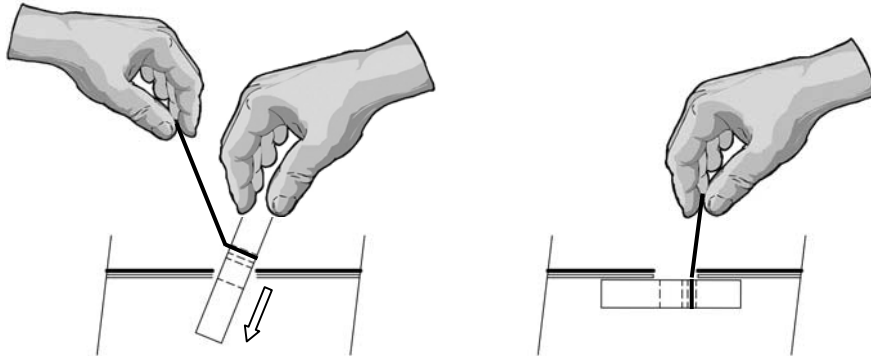

**Step Three:** When the elongated nut is fully through the hole, pull the plastic tie back, pressing the elongated nut against the under side of the purlin, enabling the threaded hole of the nut to be exposed.

**Step Four:** Using your other hand, take the preassembled anchor and commence screwing the threaded bar into the restrained elongated nut in a clockwise direction. Once the threaded section has received at least 5 turns, release the plastic tie and cut it flush with the roof sheeting (if it does not fall through the hole).

### Diagram Three

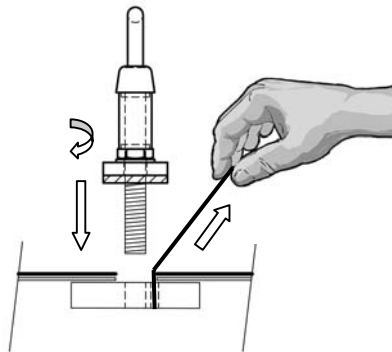

**In an effort to improve the water seal and overcome imperfections in the roof sheeting, it may be advisable to apply a layer of a suitable sealant between the rubber gasket and the roof sheet prior to tightening.**

**Step Five:** Screw the assembly down to the roof, ensuring a tight fit to a torque setting of at least 140Nm, by screwing the eye bolt, using a bar.

**Note:** Ensure that the eyelet is oriented correctly during final tightening.

**Diagram Four**

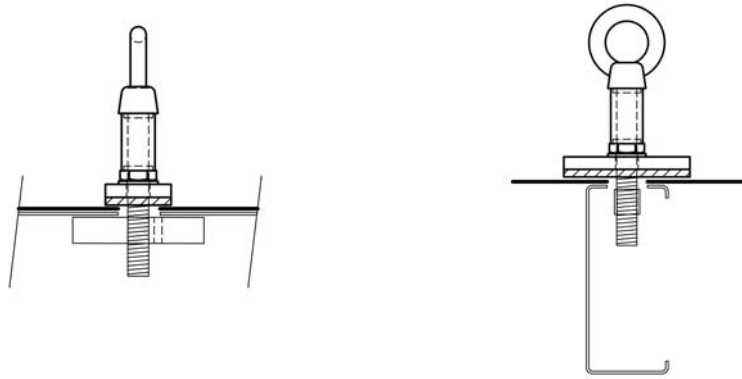

**Step Six:** Secure the data tag to the stainless steel tube using the plastic ties. All roof anchors are required by law to be inspected and recertified for use annually. Further details can be obtained from AS/NZS 1891.4:2000.

**Diagram Five**

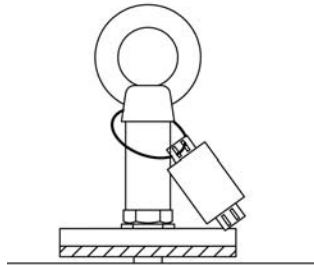

Alternatively, contact Sala on 1800 245 002 if you require any details regarding the certification of anchor points. Additional inspection data tags can be purchased from your local Sala distributor.

## Option B: Fitting from under the roof

Two persons are required to complete the installation in this manner. One person will be needed on the top of the roof to install the preassembled anchor point, whilst the person below completes the drilling and locating of the elongated nut.

**Step One:** Either the person on top or below should drill an 18mm hole in the roof sheet and purlin.

**Step Two:** The person on the top of the roof should then insert the preassembled anchor point into the 18mm hole. The person underneath will position the elongated nut to the threaded bar, then instruct the person on top to commence screwing the thread in a clockwise direction.

**Diagram Six**

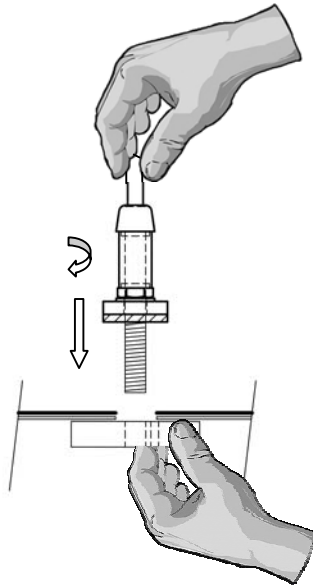

**In an effort to improve the water seal and overcome imperfections in the roof sheeting, it may be advisable to apply a layer of a suitable sealant between the rubber gasket and the roof sheet prior to tightening.**

**Step Three:** Once the anchor point has been tightened firmly by hand, the person on the top of the roof should then screw the assembly down to a torque setting of at least 140Nm, by screwing the eye bolt further, using a bar.

**Note:** Ensure that the eyelet is oriented correctly during final tightening.

**Diagram Seven**

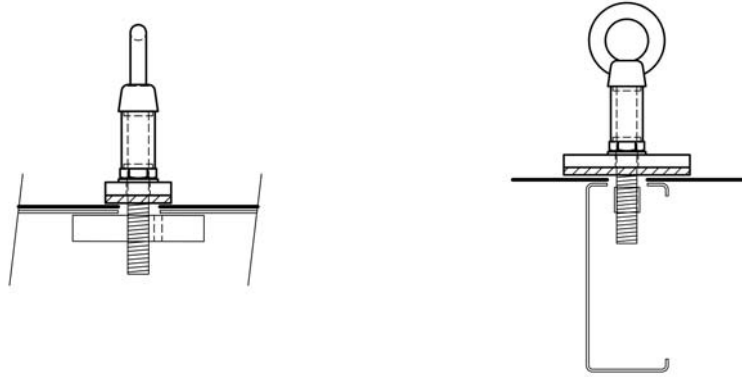

**Step Four:** Secure the data tag to the stainless steel tube using the plastic ties. All roof anchors are required by law to be inspected and recertified for use annually. Further details can be obtained from AS/NZS 1891.4:2000.

**Diagram Eight**



Alternatively, contact Sala on 1800 245 002 if you require any details regarding the certification of anchor points. Additional inspection data tags can be purchased from your local Sala distributor.